

## TROUBLESHOOTING

### TROUBLE SHOOTING

#### General Information:

**Environmental Factors** - There are a number of factors that will affect your desired comfort level. These factors can include insulation, open or drafty doors and windows, and outside temperature. Please check and take action if any of these potential problems are affecting your heaters ability to adequately warm your room.

**Supplemental Heat** - Portable electric heaters are intended for supplemental heating of rooms to heat the room your in and turn down the central heat thermostat. They are not intended to replace central heating systems.

**Do NOT attempt to repair or adjust any electrical or mechanical functions on this heater. Doing so will void warranty. The inside of the heater contains no user serviceable parts. All servicing should be performed by qualified personnel only.**

Troubleshooting for your Heater		
Trouble	Probable Cause	Solution
<ul style="list-style-type: none"> <li>Heater Does Not Turn On.</li> </ul>	<ul style="list-style-type: none"> <li>Timer Activated.</li> <li>Manual user reset is activated.</li> <li>Not plugged in properly.</li> <li>Electrical outlet does not hold plug in securely.</li> <li>Thermostat set too low.</li> <li>Obstruction causing the heater not to operate.</li> <li>Circuit breaker trips.</li> </ul>	<ul style="list-style-type: none"> <li>Press the Mode Button (⏻/Mode) to Turn on the Heater.</li> <li>Follow reset instructions listed in this manual.</li> <li>Ensure plug is properly inserted. Make sure electrical outlet and circuit breaker are working.</li> <li>Have outlet replaced by a licensed electrician.</li> <li>Press the Up (▲) Button to the highest temperature setting.</li> <li>Unplug the heater and remove all obstructions. Position your heater 36 inches away from all objects.</li> <li>Make sure no other high wattage appliances are operating on the same circuit and reset breaker if needed.</li> </ul>
<ul style="list-style-type: none"> <li>Power light is flashing or in some cases, Heater Turns On at High Heat setting but then Shuts Off in 2 seconds with Power Light Flashing.</li> </ul>	<ul style="list-style-type: none"> <li>Auto Safety Shut-off system is activated when there is potential overheat.</li> <li>Tip-over switch engaged.</li> </ul>	<ul style="list-style-type: none"> <li>Follow Auto Safety Shut-off instructions to reset the heater and allow sufficient time for the heater to cool down before plugging in again.</li> <li>Set heater upright on a level surface.</li> </ul>

## TROUBLESHOOTING

Troubleshooting for your Heater		
Trouble	Probable Cause	Solution
<ul style="list-style-type: none"> <li>Not Enough Heat.</li> </ul>	<ul style="list-style-type: none"> <li>Heater is in Low Heat setting.</li> <li>Thermostat set too low.</li> </ul>	<ul style="list-style-type: none"> <li>Change setting to High Heat.</li> <li>Press the Up (▲) Button to the highest temperature setting.</li> </ul>
<ul style="list-style-type: none"> <li>Heater cycles ON and OFF frequently.</li> </ul>	<ul style="list-style-type: none"> <li>The thermostat automatically turns the heater on and off to maintain selected comfort level.</li> <li>Every 10 minutes the heater turns on and runs for 3 minutes.</li> </ul>	<ul style="list-style-type: none"> <li>To make this occur less frequently press the Up (▲) Button to the highest setting.</li> <li>This is normal operation to ensure the heater is maintaining the room temp accurately. Such kind of cycling will repeat for 3 times only for every power on.</li> </ul>
<ul style="list-style-type: none"> <li>Remote Does not work.</li> </ul>	<ul style="list-style-type: none"> <li>Battery low.</li> <li>Distance too far.</li> <li>Control Panel Display dirty.</li> </ul>	<ul style="list-style-type: none"> <li>Change battery (Disc type, 3 volt, CR2025).</li> <li>Remote works up to 20 feet.</li> <li>Be sure to point remote at control panel on heater and there are no obstructions.</li> <li>Make sure display panel is clean.</li> </ul>
<ul style="list-style-type: none"> <li>Heater is Blowing Cold Air.</li> </ul>	<ul style="list-style-type: none"> <li>When the heater is in Thermostat Mode and reaches the set temperature it will automatically perform a 10 second cool down (blowing cold air) to ensure thermostat accuracy.</li> <li>Unit is in the Fan Only setting.</li> <li>Mode Button (⏻/Mode) may have been pressed to turn off the heater.</li> </ul>	<ul style="list-style-type: none"> <li>Raise the temperature higher or change setting to Low or High heat.</li> <li>Press the Mode Button (⏻/Mode) to select High Heat or Low Heat settings.</li> <li>Press the Mode Button (⏻/Mode) to turn on the heater.</li> </ul>
<ul style="list-style-type: none"> <li>Fan Speed Doesn't Change.</li> </ul>	<ul style="list-style-type: none"> <li>High Heat and Low Heat/Eco-Smart™ settings control the heat output of the heater and not the fan speed. Fan runs at the same speed on all settings.</li> </ul>	<ul style="list-style-type: none"> <li>Run heater in High Heat for maximum heat output.</li> </ul>
<ul style="list-style-type: none"> <li>Unexpected Noise.</li> </ul>	<ul style="list-style-type: none"> <li>You may hear a popping or crackling sound as the heater heats up. This is normal and safe operation. Once the heater heats up, the crackling sound will go away.</li> </ul>	<ul style="list-style-type: none"> <li>If the noise persists call Bionaire at 1-800-253-2764.</li> </ul>
<ul style="list-style-type: none"> <li>Unexpected Smell.</li> </ul>	<ul style="list-style-type: none"> <li>There may be an odor or vapor coming from the heater the first time you use it or after prolonged or seasonal storage.</li> </ul>	<ul style="list-style-type: none"> <li>This is normal and is the result of dust or other debris accumulating on the heating element. Make sure the heater is in a well ventilated area and continue running until the odor or vapor goes away.</li> </ul>

## WARRANTY INFORMATION

### 1 YEAR LIMITED WARRANTY

Sunbeam Products, Inc. doing business as Jarden Consumer Solutions or if in Canada, Sunbeam Corporation (Canada) Limited doing business as Jarden Consumer Solutions (collectively "JCS") warrants that for a period of one year from the date of purchase, this product will be free from defects in material and workmanship. JCS, at its option, will repair or replace this product or any component of the product found to be defective during the warranty period. Replacement will be made with a new or remanufactured product or component. If the product is no longer available, replacement may be made with a similar product of equal or greater value. This is your exclusive warranty. Do NOT attempt to repair or adjust any electrical or mechanical functions on this product. Doing so will void this warranty.

This warranty is valid for the original retail purchaser from the date of initial retail purchase and is not transferable. Keep the original sales receipt. Proof of purchase is required to obtain warranty performance. JCS dealers, service centers, or retail stores selling JCS products do not have the right to alter, modify or any way change the terms and conditions of this warranty.

This warranty does not cover normal wear of parts or damage resulting from any of the following: negligent use or misuse of the product, use on improper voltage or current, use contrary to the operating instructions, disassembly, repair or alteration by anyone other than JCS or an authorized JCS service center. Further, the warranty does not cover: Acts of God, such as fire, flood, hurricanes and tornadoes.

#### What are the limits on JCS's Liability?

JCS shall not be liable for any incidental or consequential damages caused by the breach of any express, implied or statutory warranty or condition.

Except to the extent prohibited by applicable law, any implied warranty or condition of merchantability or fitness for a particular purpose is limited in duration to the duration of the above warranty.

JCS disclaims all other warranties, conditions or representations, express, implied, statutory or otherwise.

JCS shall not be liable for any damages of any kind resulting from the purchase, use or misuse of, or inability to use the product including incidental, special, consequential or similar damages or loss of profits, or for any breach of contract, fundamental or otherwise, or for any claim brought against purchaser by any other party.

Some provinces, states or jurisdictions do not allow the exclusion or limitation of incidental or consequential damages or limitations on how long an implied warranty lasts, so the above limitations or exclusion may not apply to you.

This warranty gives you specific legal rights, and you may also have other rights that vary from province to province, state to state or jurisdiction to jurisdiction.

#### How to Obtain Warranty Service

##### In the U.S.A.

If you have any questions regarding this warranty or would like to obtain warranty service, please call 1-800-253-2764 and a convenient service center address will be provided to you.

##### In Canada

If you have any questions regarding this warranty or would like to obtain warranty service, please call 1-800-253-2764 and a convenient service center address will be provided to you.

If you have any questions regarding your product or would like to learn more about other Bionaire® products, please contact our Consumer Service Department at 1-800-253-2764 or visit our website at [www.bionaire.com](http://www.bionaire.com).

## WARRANTY INFORMATION

In the U.S.A., this warranty is offered by Sunbeam Products, Inc. doing business as Jarden Consumer Solutions located in Boca Raton, Florida 33431. In Canada, this warranty is offered by Sunbeam Corporation (Canada) Limited doing business as Jarden Consumer Solutions, located at 20 B Hereford Street, Brampton, Ontario L6Y 0M1. If you have any other problem or claim in connection with this product, please write our Consumer Service Department. **PLEASE DO NOT RETURN THIS PRODUCT TO ANY OF THESE ADDRESSES OR TO THE PLACE OF PURCHASE.**



pure indoor living



MODEL: BCH9208

## BIONAIRE® HEATER

**NOTE:** A Phillips screwdriver is required for assembly.

### Instruction Leaflet

Read instructions before operating. Retain for future reference.

Questions? Comments? Call 1-800-253-2764 in North America.

© 2011 Sunbeam Products, Inc. doing business as Jarden Consumer Solutions. All Rights Reserved. Distributed by Sunbeam Products, Inc. doing business as Jarden Consumer Solutions, Boca Raton, Florida 33431.

148085/9100020013086  
GCD5-BIO22466-PH

BCH9208-U\_11EM2

Printed In China

## PLEASE READ AND SAVE THESE IMPORTANT SAFETY INSTRUCTIONS

When using electrical appliances, basic safety precautions should always be followed to reduce the risk of fire, electric shock, and injury to persons, including the following:

1. Read all instructions before using this heater.
2. This heater is hot when in use. To avoid burns, do not let bare skin touch hot surfaces. If provided, use handles when moving this heater. Keep combustible materials, such as furniture, pillows, bedding, papers, clothes, and curtains at least 3 feet (0.9 m) from the front of the heater and keep them away from the sides and rear.
3. Extreme caution is necessary when any heater is used by or near children or invalids and whenever the heater is left operating and unattended.
4. Always unplug heater when not in use.
5. Do not operate any heater with a damaged cord or plug or after the heater malfunctions, has been dropped or damaged in any manner. Discard heater, or return to authorized service facility for examination and/or repair.
6. Do not use outdoors.
7. This heater is not intended for use in bathrooms, laundry areas and similar indoor locations. Never locate heater where it may fall into a bathtub or other water container.
8. Do not run cord under carpeting. Do not cover cord with throw rugs, runners, or similar coverings. Do not route cord under furniture or appliances. Arrange cord away from traffic area and where it will not be tripped over.
9. To disconnect heater, turn controls to off, then remove plug from outlet.
10. Do not insert or allow foreign objects to enter any

ventilation or exhaust opening as this may cause an electric shock or fire, or damage the heater.

11. To prevent a possible fire, do not block air intakes or exhaust in any manner. Do not use on soft surfaces, like a bed, where openings may become blocked.
12. A heater has hot and arcing or sparking parts inside. Do not use it in areas where gasoline, paint, or flammable liquids are used or stored.
13. Use this heater only as described in this manual. Any other use not recommended by the manufacturer may cause fire, electric shock, or injury to persons.
14. Always plug heaters directly into a wall outlet/receptacle. Never use with an extension cord or relocatable power tap (outlet/power strip).
15. When unplugging, be sure to pull by the plug and not the cord.
16. If the heater will not operate, see specific instructions on Auto Safety Shut-off.
17. DO NOT attempt to repair or adjust any electrical or mechanical functions on this unit. Doing so will void your warranty. The inside of the unit contains no user serviceable parts. All servicing should be performed by qualified personnel only.
18. Discontinue use if plug or outlet is hot. It is recommended that the outlet be replaced if plug or outlet is hot to touch.
19. The heater must not be located immediately below a socket-outlet. Do not use this heater in the immediate surroundings of a bath, a shower or a swimming pool.

## SAVE THESE INSTRUCTIONS

**THIS APPLIANCE HAS A POLARIZED PLUG (one blade is wider than the other). To reduce the risk of electric shock, this plug is intended to fit in a polarized outlet only one way. If the plug does not fit fully in the outlet, reverse the plug. If it still does not fit, contact a qualified electrician to install the proper outlet.**

**DO NOT ATTEMPT TO MODIFY THIS PLUG OR DEFEAT THIS SAFETY FEATURE IN ANY WAY.**

## ASSEMBLY INSTRUCTIONS

### TECHNICAL SPECIFICATIONS

- Amps: 12.5
- Wattage: 1500W (+5% -10%)
- Working voltage: 120V AC/60Hz

### ASSEMBLY INSTRUCTIONS

**NOTE:** A Phillips screwdriver is required for assembly. Unpack your heater from the box, being careful to remove all parts from plastic bags and remaining packaging. Please save the carton for off-season storage. Your heater is packed with separate base in the box. Carefully remove all parts from plastic bags. To prevent scratches, place all parts onto a cloth before assembly. Follow the below instructions for Base assembly:

#### Base Assembly

- Step 1: Run the power cord through the center of the base. To assemble the base to the unit, first make sure the side marked "Rear" is facing the back of the heater. Line up holes of the base with holes of the heater bottom, and secure with 4 provided screws. Refer to Figure 1.
- Step 2: Lace the power cord through the cord minders on the underside of the base. Refer to Figure 2.
- Step 3: Turn the heater right side up on a flat level surface prior to beginning operation.

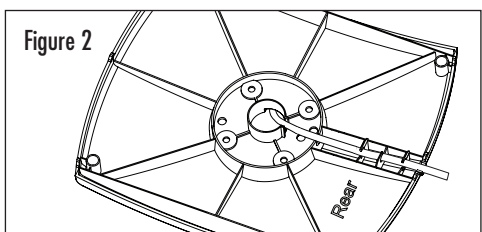
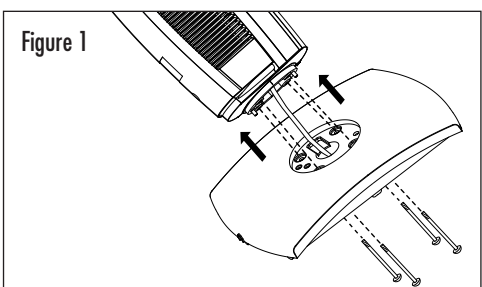

#### Remote Control

Unpack the remote control from box. This includes one lithium battery, CR2025/3V. Please note this remote control will not work through walls. Remove battery before discarding the remote.

**NOTE: REMOVE THE PROTECTIVE COVER FROM THE BATTERY PRIOR TO BEGINNING OPERATION.**

## FEATURES - OPERATIONS

### Battery Replacement

1. Locate the battery compartment on the back of the remote control handset. Insert a small object (such as a pin or paper clip) into the hole of the battery cover lock (see Figure 3) and slide out the battery cover.

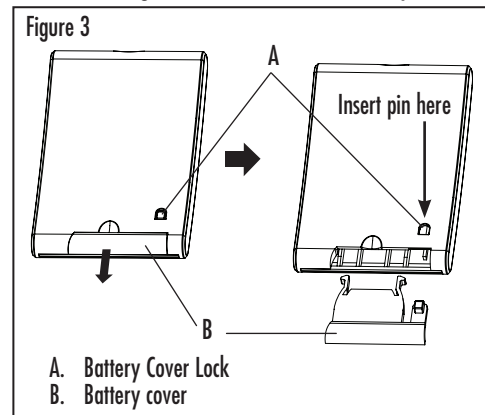

2. Remove old battery.
3. Place new battery into battery compartment.
4. Slide battery compartment into the remote control handset until the Battery Cover Lock is securely latched.
5. For your convenience, a remote control holder is integrated into the back of the heater housing.

#### NOTES:

- THIS PRODUCT CONTAINS A BUTTON BATTERY. IF SWALLOWED, IT COULD CAUSE SEVERE INJURY IN JUST 2 HOURS. SEEK MEDICAL ATTENTION IMMEDIATELY.
- Remove the battery from the equipment when it is not being used for an extended period of time.
- Remove the used battery promptly.
- Do not discard used batteries into household trash containers. Contact your local government for disposal or recycling practices in your area.

### FCC STATEMENT

#### Potential for Radio/Television Interference

This device complies with Part 15 of the FCC Rules. Operation is subject to the following two conditions: (1) This device may not cause harmful interference, and (2) this device must accept any interference received, including interference that may cause undesired operation.

This product has been tested and found to comply with the limits for a Class B digital device, pursuant to part 15 of the FCC rules.

These limits are designed to provide reasonable protection against harmful interference in a residential installation. The product generates, uses, and can radiate radio frequency energy and, if not installed and used in accordance with the instructions, may cause harmful interference to radio communications. However, there is no guarantee that the interference will not occur in a particular installation. If the product does cause harmful interference to radio or television reception, which can be determined by turning the product on or off, the user is encouraged to try to correct the interference by one or more of the following measures:

- Reorient or relocate the receiving antenna.
- Increase the separation between the product and the receiver.
- Connect the product into an outlet on a circuit different from that to which the receiver is connected.
- Consult the dealer or an experienced radio/TV technician for help.
- Changes or modifications not expressly approved by the party responsible for compliance could void the user's authority to operate the equipment.

## FEATURES - OPERATIONS

### OPERATING INSTRUCTIONS

1. Carefully remove your heater from the box. Please save the carton for off-season storage.
2. Place heater on a firm, level surface.
3. Plug heater into a standard outlet. Once plugged in, the Power Light will illuminate.

**NOTE:** Avoid overloading your circuit by not using other high wattage appliances in the same outlet. At 1500 watts, this unit draws 12.5 Amps.

#### Mode Control

Press the Mode Button (⏻/Mode) on the control panel to select your desired heat settings. Each press of the button will cycle through the below settings and the selected setting will appear on the LCD. To operate with the remote control, first press the Power Button (⏻) on the remote and then press the Mode Button to cycle through the below settings:

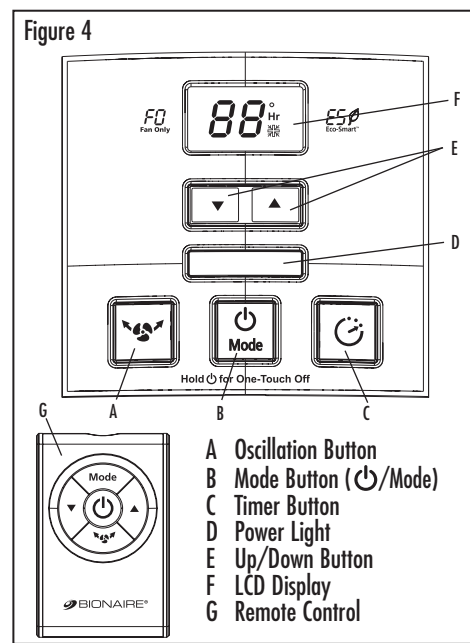

#### HI - HIGH Heat

The heater will run continuously at 1500W.

#### LO - LOW Heat

The heater will run continuously at 750W.

#### ES - Eco-Smart™ Setting

The heater will now cycle between high (at 1500W) and low (at 750W) heat settings to provide heat.

#### Thermostat Control

The next press of the Mode Button (⏻/Mode) will activate the thermostat setting, and the LCD will display "80°" as the default temperature setting.

Your heater is equipped with a digital thermostat that allows you to set your heater to a precise comfort level (65°F-85°F) by pressing the Up (▲) and Down (▼) Button on the control panel or remote control. The LCD Display will show the selected temperature reading. When the preset temperature is reached, the heater will shut off and cool down for 10 seconds. When the room temperature drops below the preset temperature, the heater will automatically turn on again to maintain the preset temperature level.

#### FrostProtect™ Setting

Your heater is equipped with FrostProtect™. The heater will turn on automatically when the room temperature drops below 40°F. To activate FrostProtect™, press the Down (▼) Button until the LCD Display show "40" and the FrostProtect™ icon (❄️) will appear on the LCD Display.

#### FO - Fan Only Setting

Press the Mode Button (⏻/Mode) again to activate Fan Only setting. The heater will run at fan-only operation without heat output.

**NOTE:** To shut unit off at any time, press and hold the Mode Button (⏻/Mode) on the control panel for 2 seconds or press the Power Button (⏻) on the remote control to shut off the heater or keep pressing the Mode Button (⏻/Mode) until the LCD Display goes OFF.

**NOTE:** It is normal for the heater to cycle ON and OFF as it maintains the preset temperature. To prevent the unit

## CLEANING / MAINTENANCE AUTO SAFETY SHUT-OFF

from cycling, you need to change the thermostat setting. The digital thermostat has memory; it will remember the last temperature setting before the heater is turned off. However, if the heater is unplugged, the digital thermostat will no longer remember the previous temperature setting. You will need to reset the digital thermostat if the heater is unplugged.

**CAUTION: FRONT GRILL IS HOT WHEN UNIT IS IN OPERATION.**

#### Set Timer

This heater is equipped with 24-Hour Auto Shut-off Timer feature. This allows you to program your heater to shut off automatically after running a defined time interval (from 0 to 24 hours).

1. Press the Timer Button (⌚) on the control panel once to activate the Timer.
2. Press the Up (▲) and Down (▼) button to adjust from 0 to 24 to select your desired time interval for the heater to shut-off automatically. The selected hour will appear on the LCD Display and the "Hr" icon will blink in 3 seconds to indicate that the selected timer is activated. The LCD Display will return to show the **preset temperature and mode setting**.
3. To cancel the Timer feature, press the Timer Button (⌚) twice within 5 seconds.

#### Oscillation

Press the Oscillation Button (🌀) either on the control panel or remote control to activate or stop the oscillation feature.

**NOTE:** Please do not manually turn the heater on the base. It is designed to turn only by motorized oscillation.

### CLEANING/MAINTENANCE

Always unplug the heater before cleaning and allow the heater to cool down.

1. Clean the unit with a soft cloth moistened with a mild soap and water solution.
2. NEVER use abrasive or flammable solvents to clean the unit.

3. After cleaning, be sure to completely dry the unit with a cloth or towel.
4. Store heater in a cool, dry location.
5. It is recommended that you store the unit in its original carton. **TIP:** Over time, dust may accumulate on the front grills. This can be removed by wiping the unit with a damp cloth.

### AUTO SAFETY SHUT-OFF

This heater is equipped with a technologically-advanced safety system that requires the user to reset the heater if there is a potential overheat situation. When a potential overheat temperature is reached, the system will automatically shut the heater off. It can only resume operation when the user resets the unit.

### RESET INSTRUCTIONS

If your heater shuts down:

- 1) Stand the unit upright.
  - 2) Unplug unit.
  - 3) Wait 30 minutes for unit to cool down.
  - 4) Plug in and operate normally.
- NOTE:** If the heater is plugged in again and Mode Button (⏻/Mode) is pressed within the 30-minute cool down period, heater will run at High Heat setting, but shut down in 2 seconds with the Power Light flashing. Please repeat the above 4 steps to reset the heater again and ensure to allow sufficient time for the thermostat to cool down.

### Tip Over Shut-Off:

When the unit is accidentally knocked over, it will instantly shut off. The unit may also shut off if it is moved or bumped. To reset, simply place the heater in an upright position, and it will operate normally.

**NOTE:** If unit does not turn on when placed in the upright position, press the Mode Button (⏻/Mode) on the control panel or press the Power Button (⏻) on remote control once and heater will resume operation.